

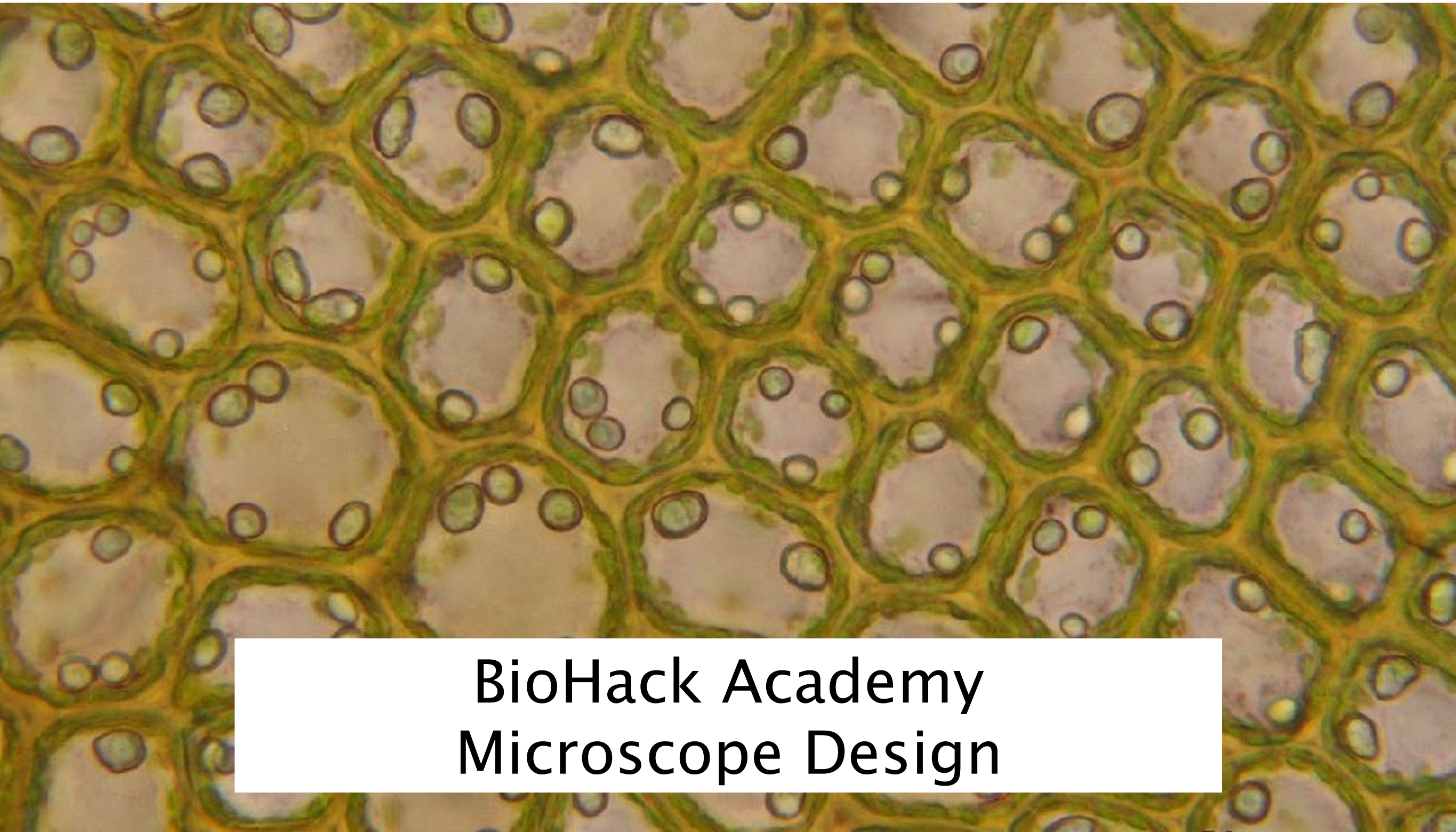

waag
wetlab amsterdam



**BioHack Academy
Microscope Design**



Why we need a microscope

- Morphological identification of organisms
- To check the purity of a culture

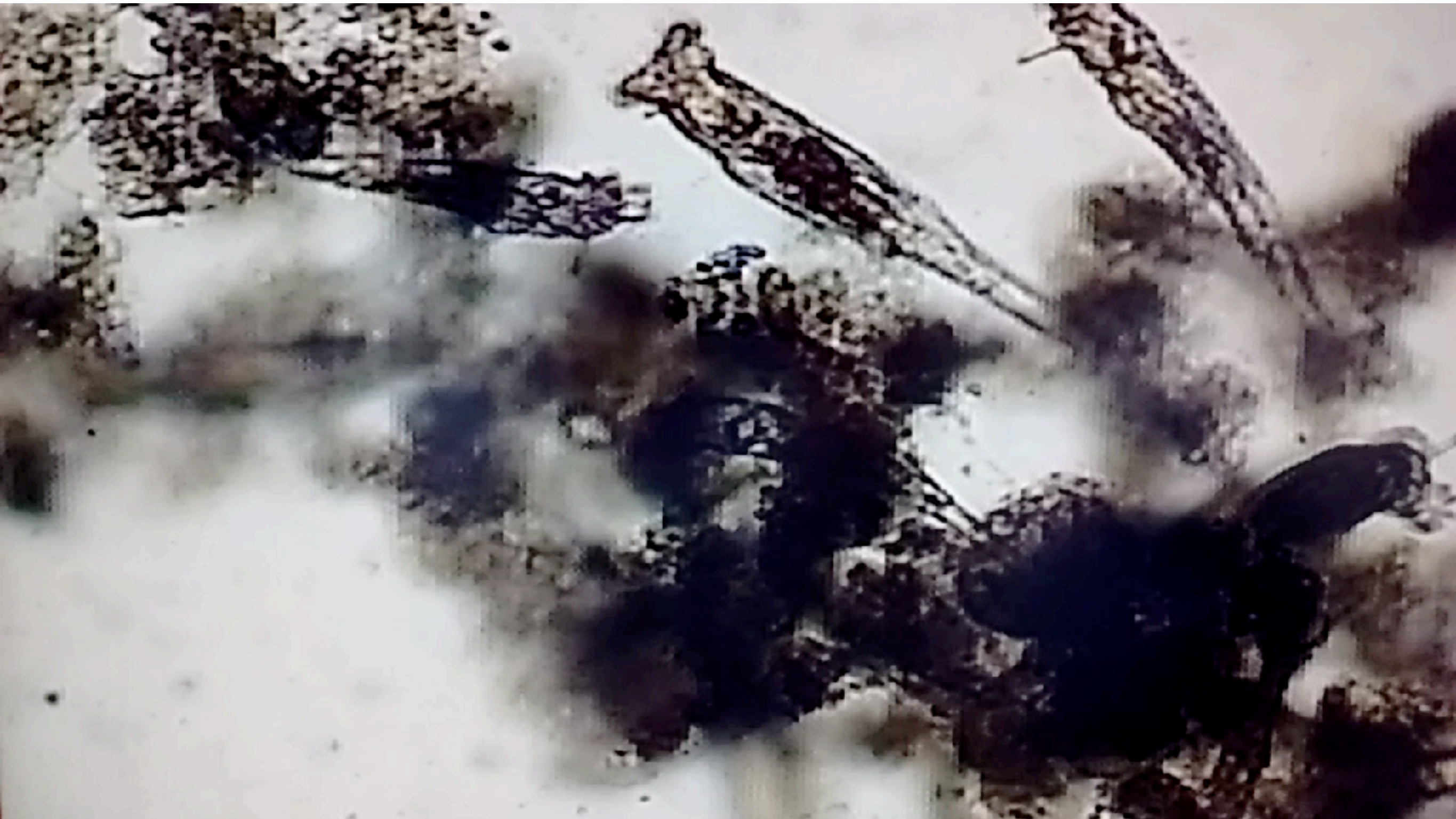



Industry Standard



Moisey - CC-BY-SA 3.0



Paul Hartzog - CC-BY-SA 2.0



Pixabay Public Domain



Design Constrains

- Microscope slide
- Make sure these fit in your design

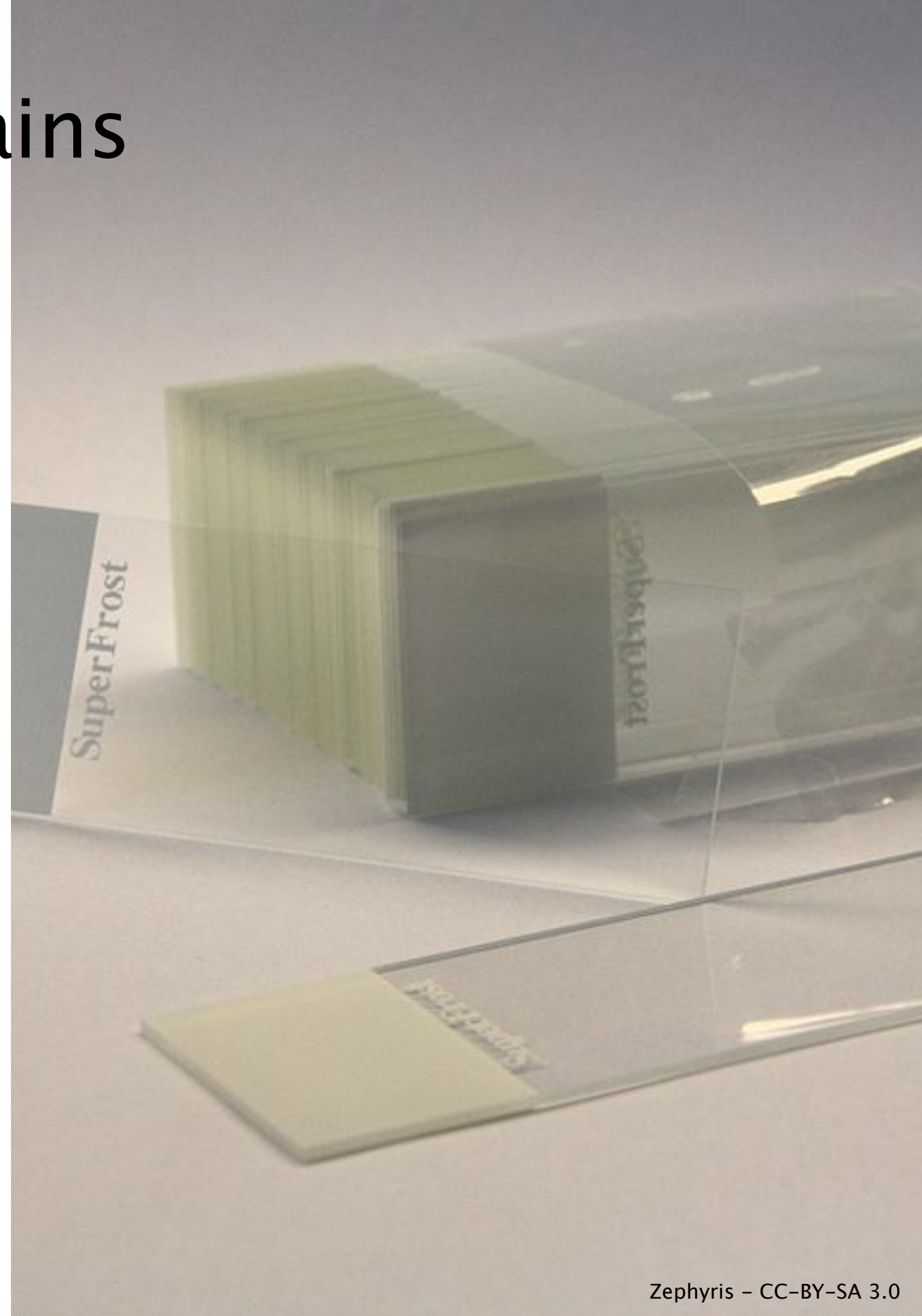



Biohack Academy Designs

You may choose which one to build

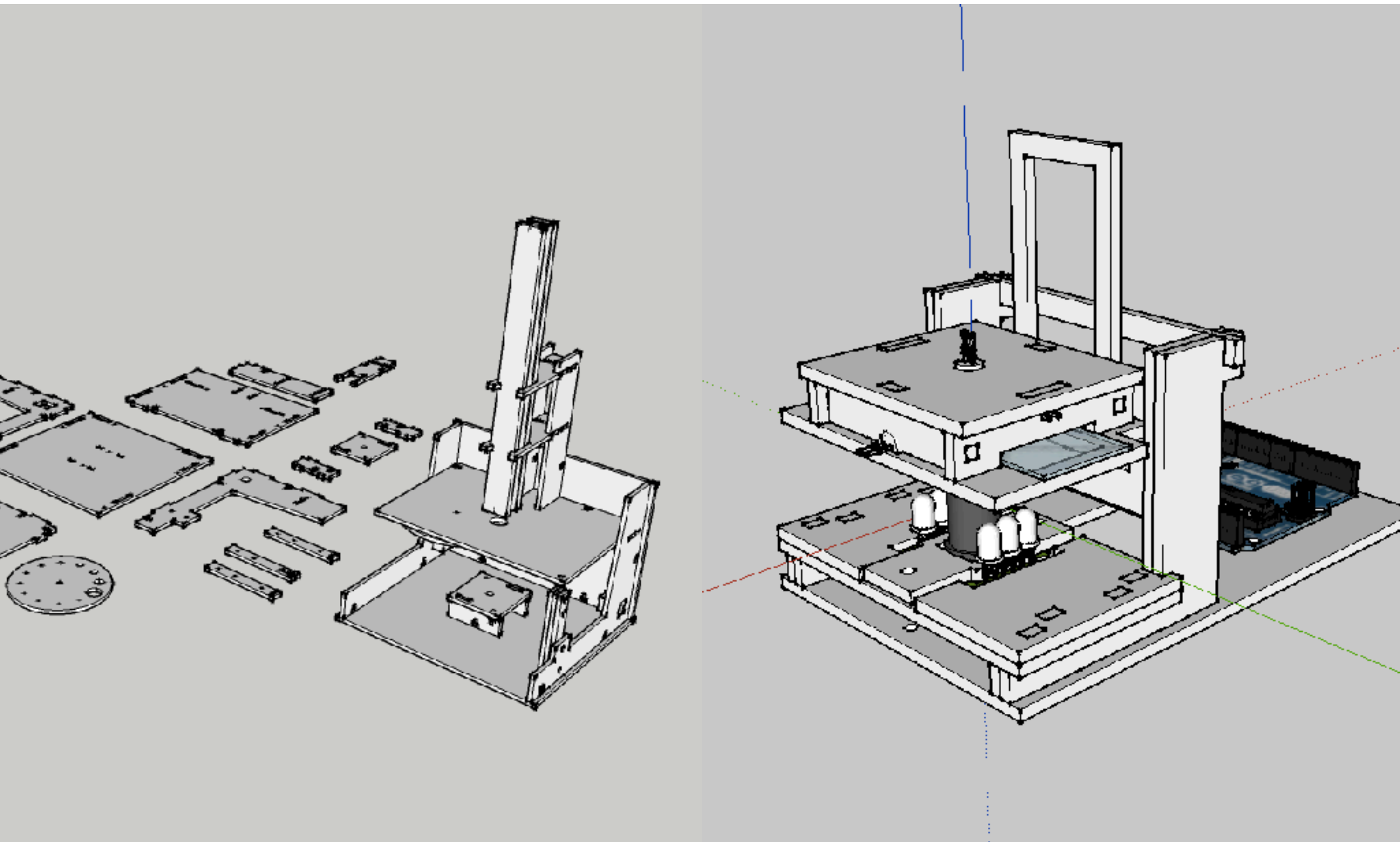



Webcam Microscope

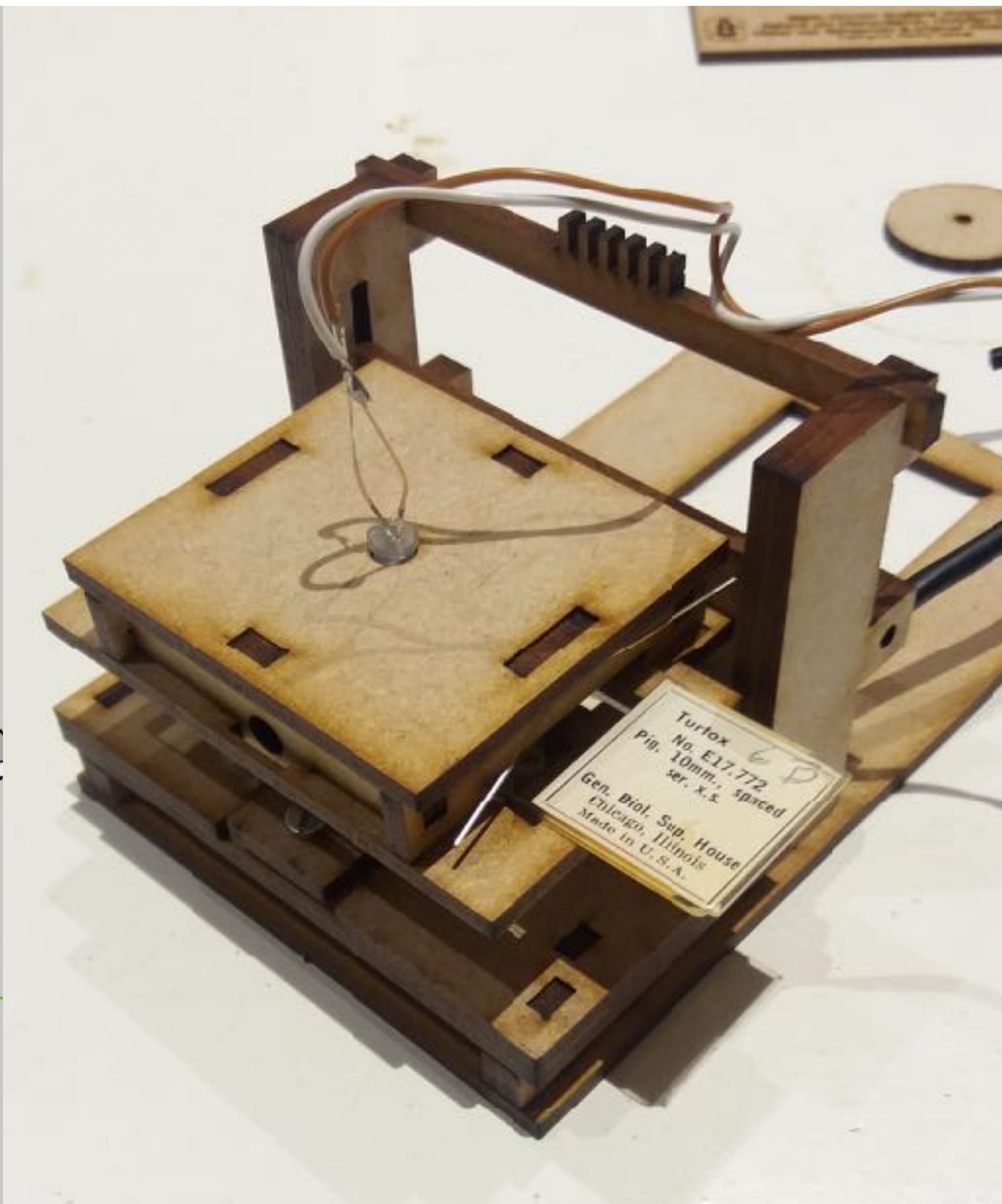
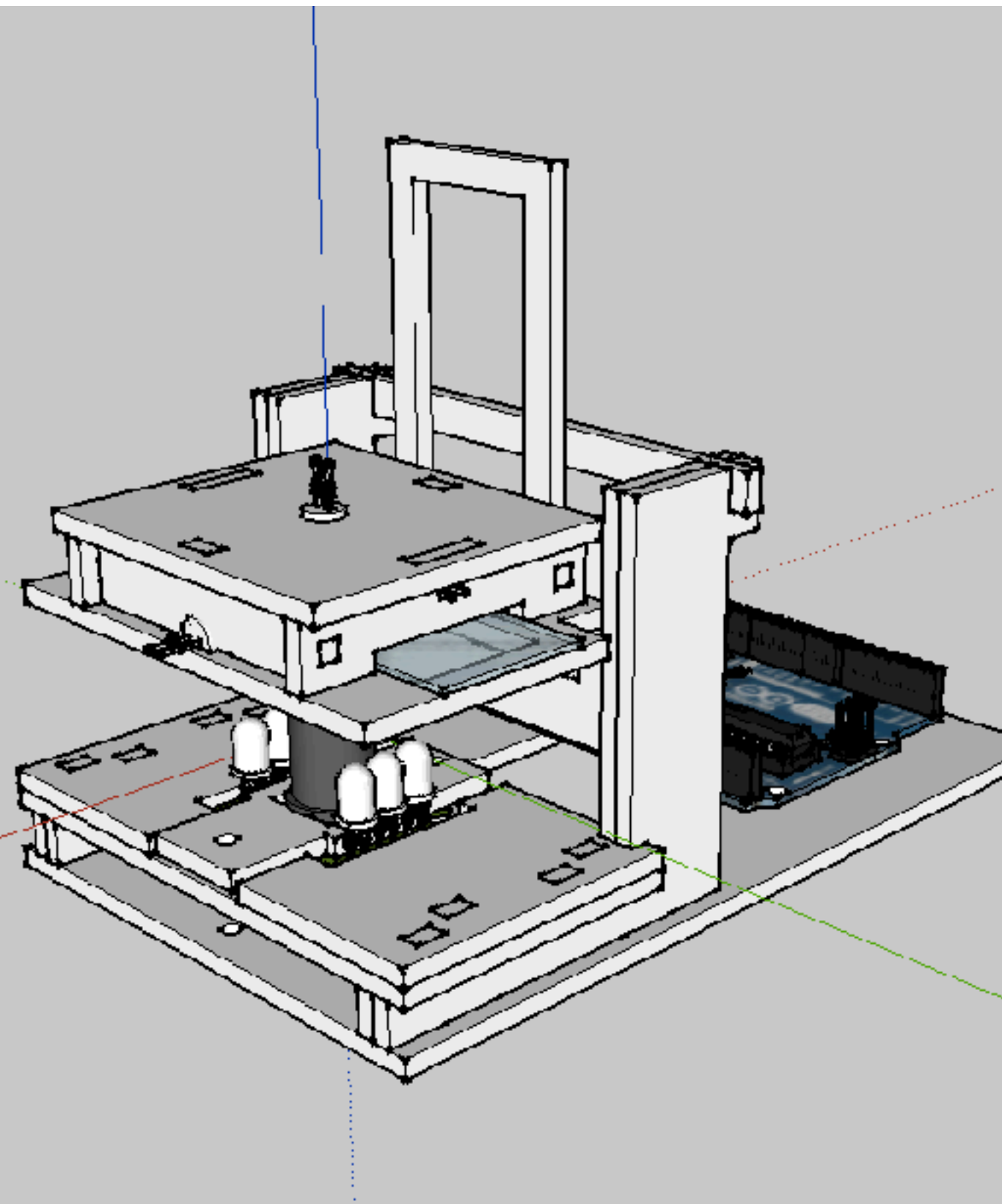



Pixel Based Magnification test

- Take a picture of your screen up close
- Count the number of pixels in the frame
- Calculate the magnification

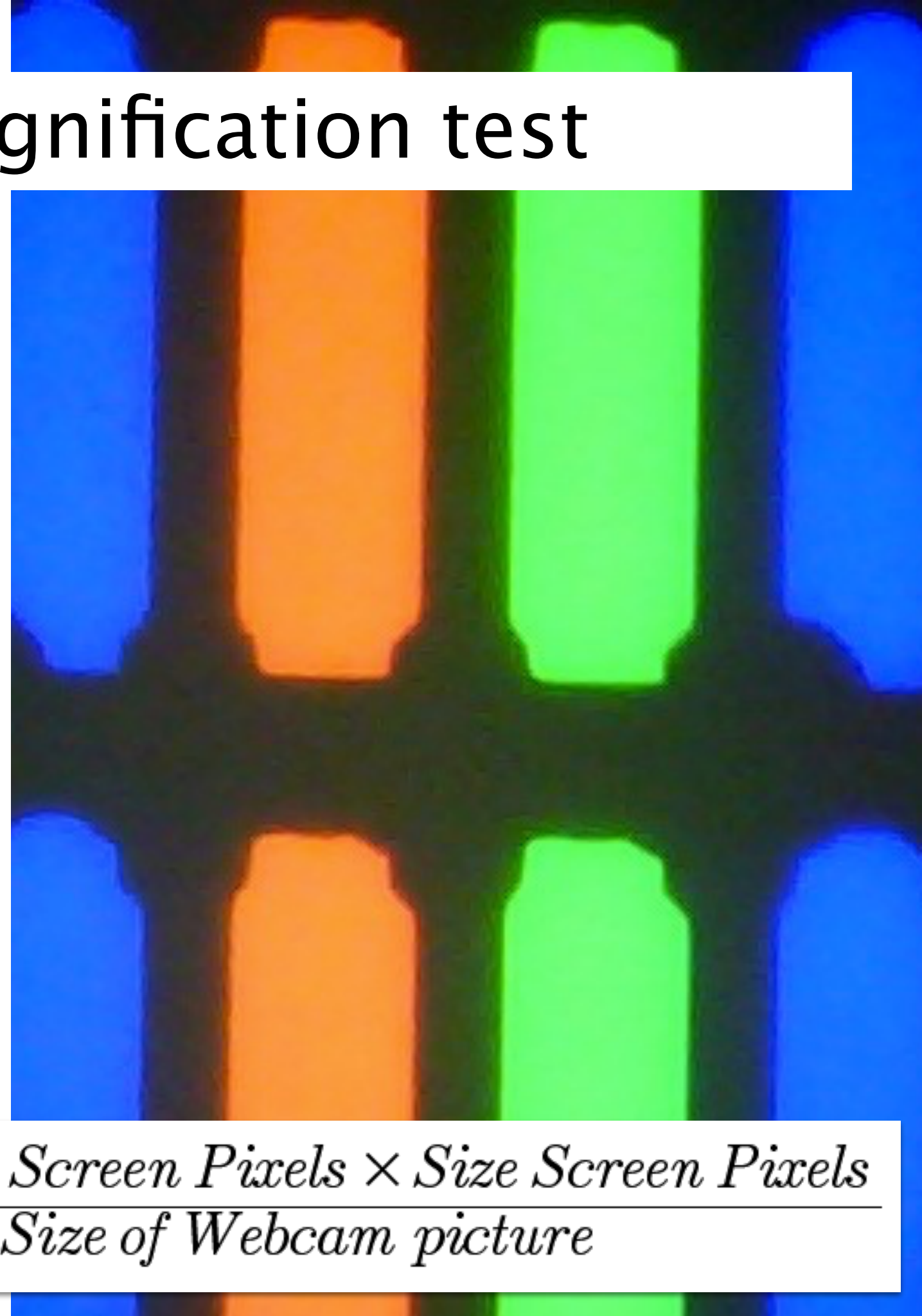

$$\text{Magnification } M = \frac{\text{Number of Screen Pixels} \times \text{Size Screen Pixels}}{\text{Size of Webcam picture}}$$



Spirulina by webcam microscope





Euglena by webcam microscope





Compound microscope

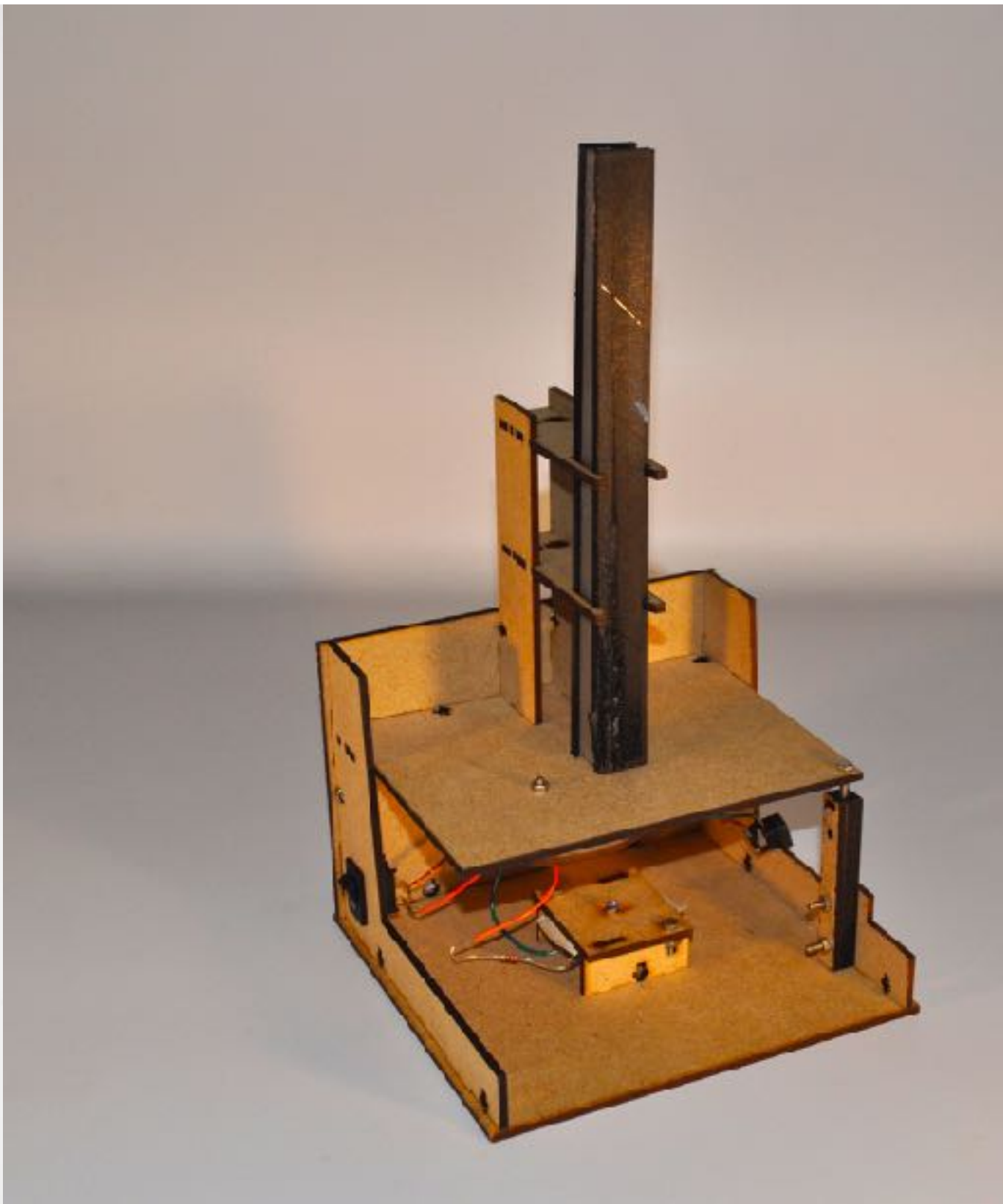



Dimensions

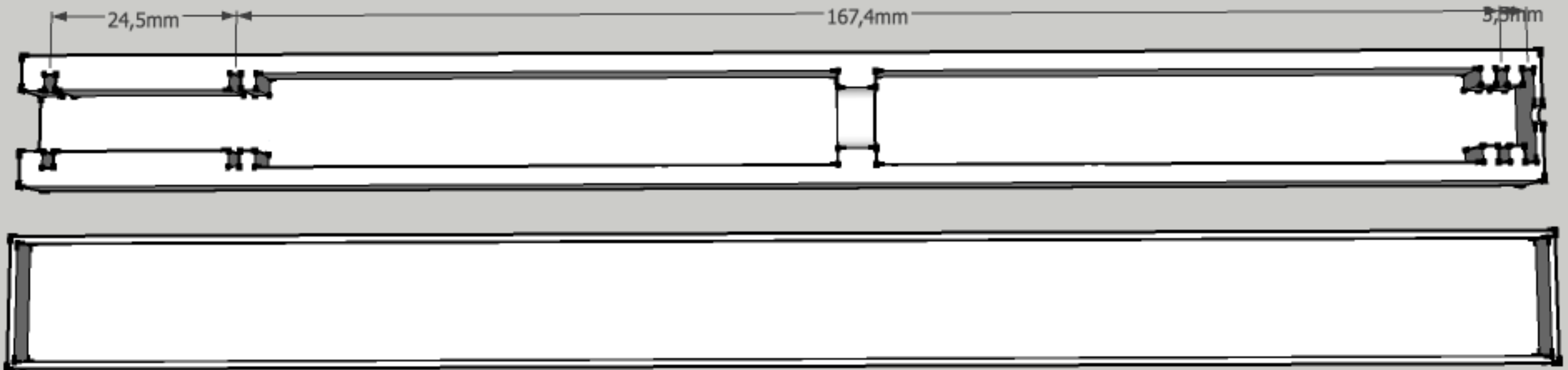



Microscope formulas

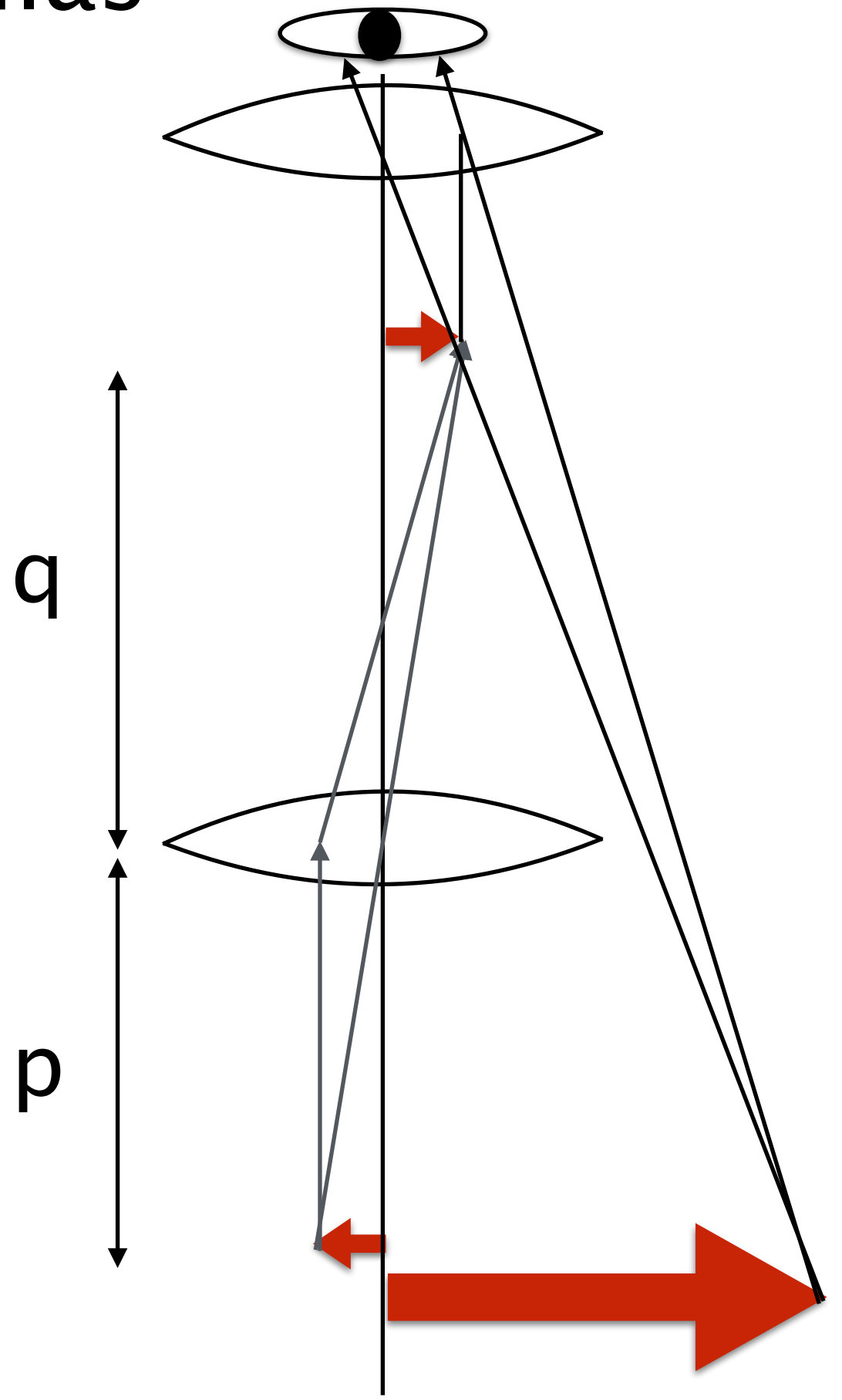
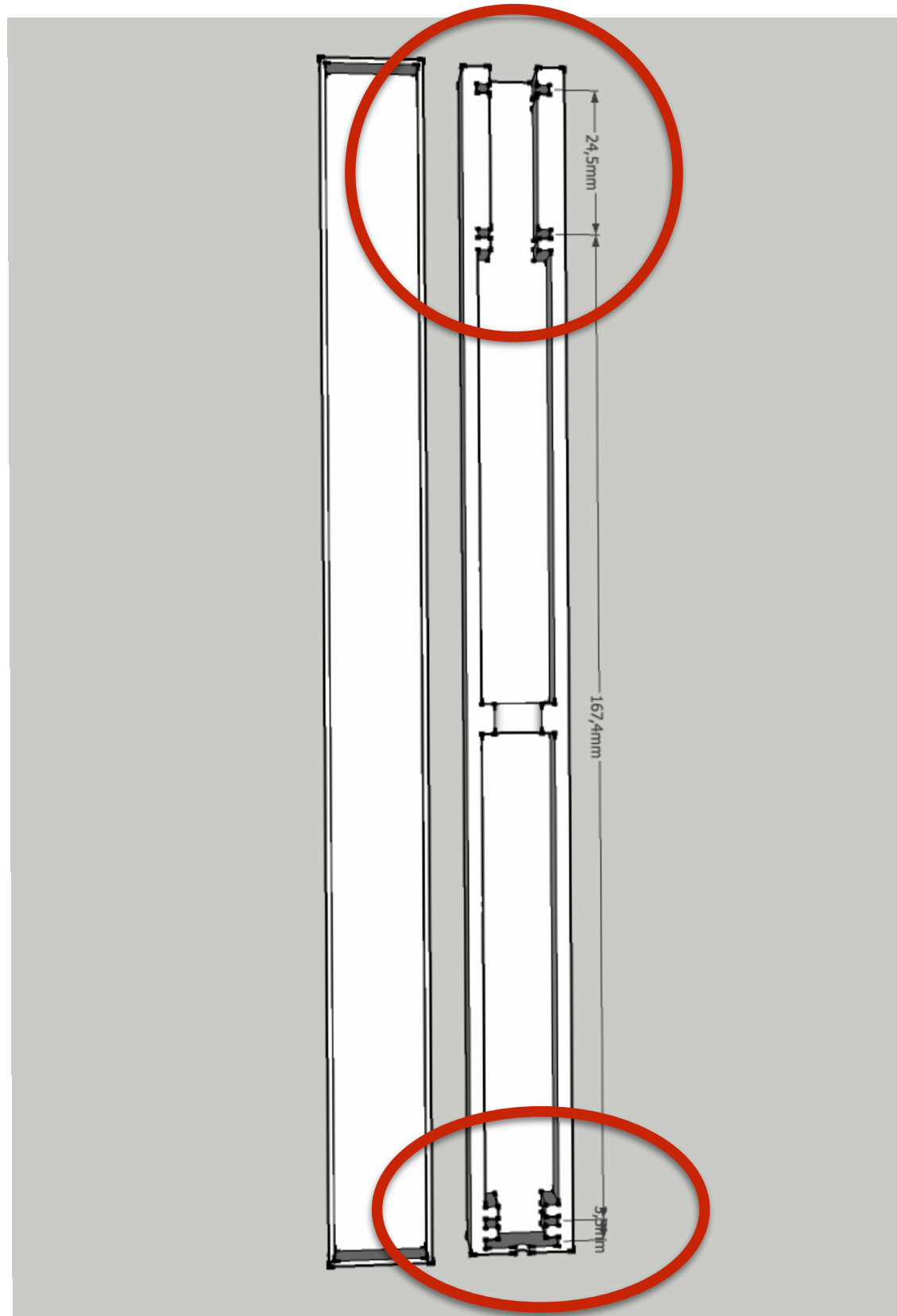



Magnification Objective

- Focal length of objective
 - $f_a = f_b = 35$ mm
 - distance = 3.2 mm
 - $f_{ab} = 18.3$ mm
- Objective-specimen distance
 - $q = 167.4$ mm (given)
 - $p = 20.6$ (calculated)
- Magnification power objective
 - $M_{ob} = 167.4 / 20.6$
 - $M_{ob} = 8.1$

$$f_{ab} = \frac{f_a \times f_b}{f_a + f_b - d}$$

$$\frac{1}{f} = \frac{1}{p} + \frac{1}{q}$$

$$M_{ob} = \frac{p}{q}$$



Magnification Eyepiece

- Focal length eyepiece
 - $f_a = f_b = 35$ mm
 - distance = 24.5 mm
 - $f_{ab} = 26,92$ mm
- $M_{ep} = 250 / 26.92$
- $M_{ep} = 9.3$

$$f_{ab} = \frac{f_a \times f_b}{f_a + f_b - d}$$

$$M_{ep} = \frac{250}{f_{ab}}$$



Magnification Microscope

- $M_{mic} = 8.1 \times 9.3$
- $M_{mic} = 75.5$

$$M_{mic} = M_{ob} \times M_e$$



Wiring

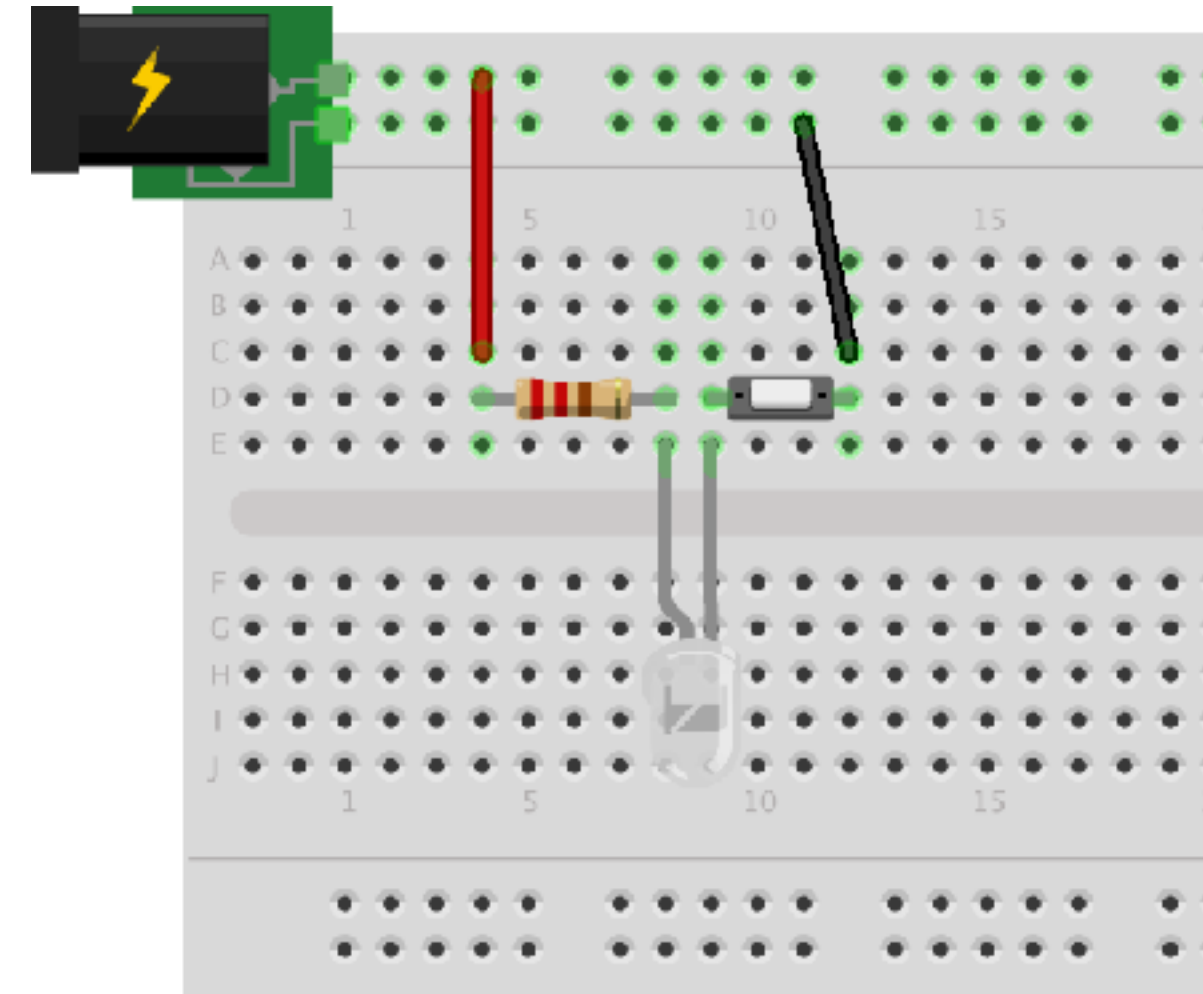
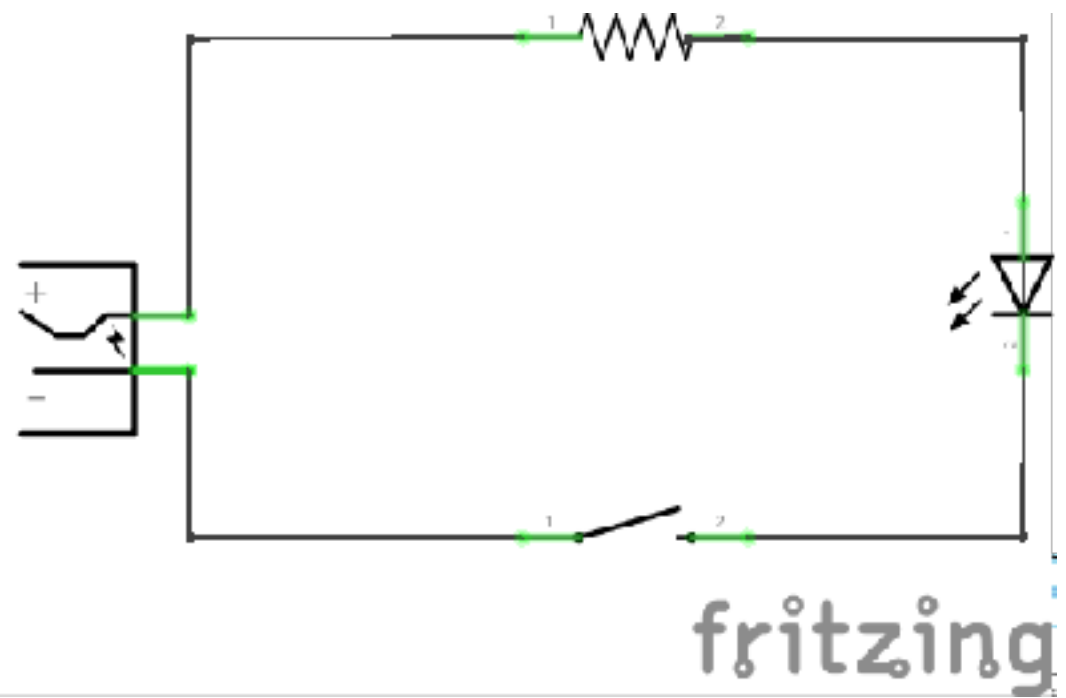



3D printing

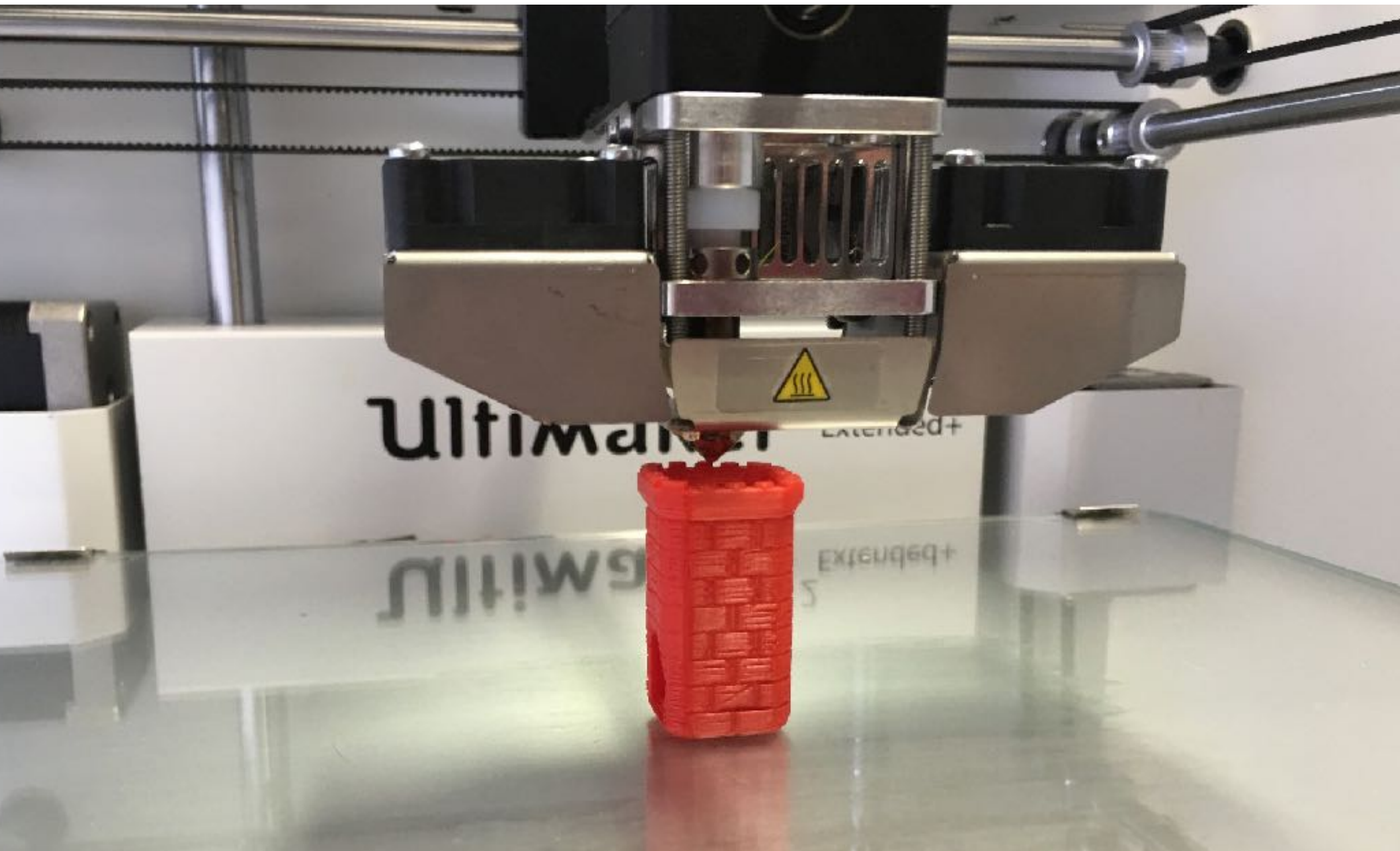



Bioprinting

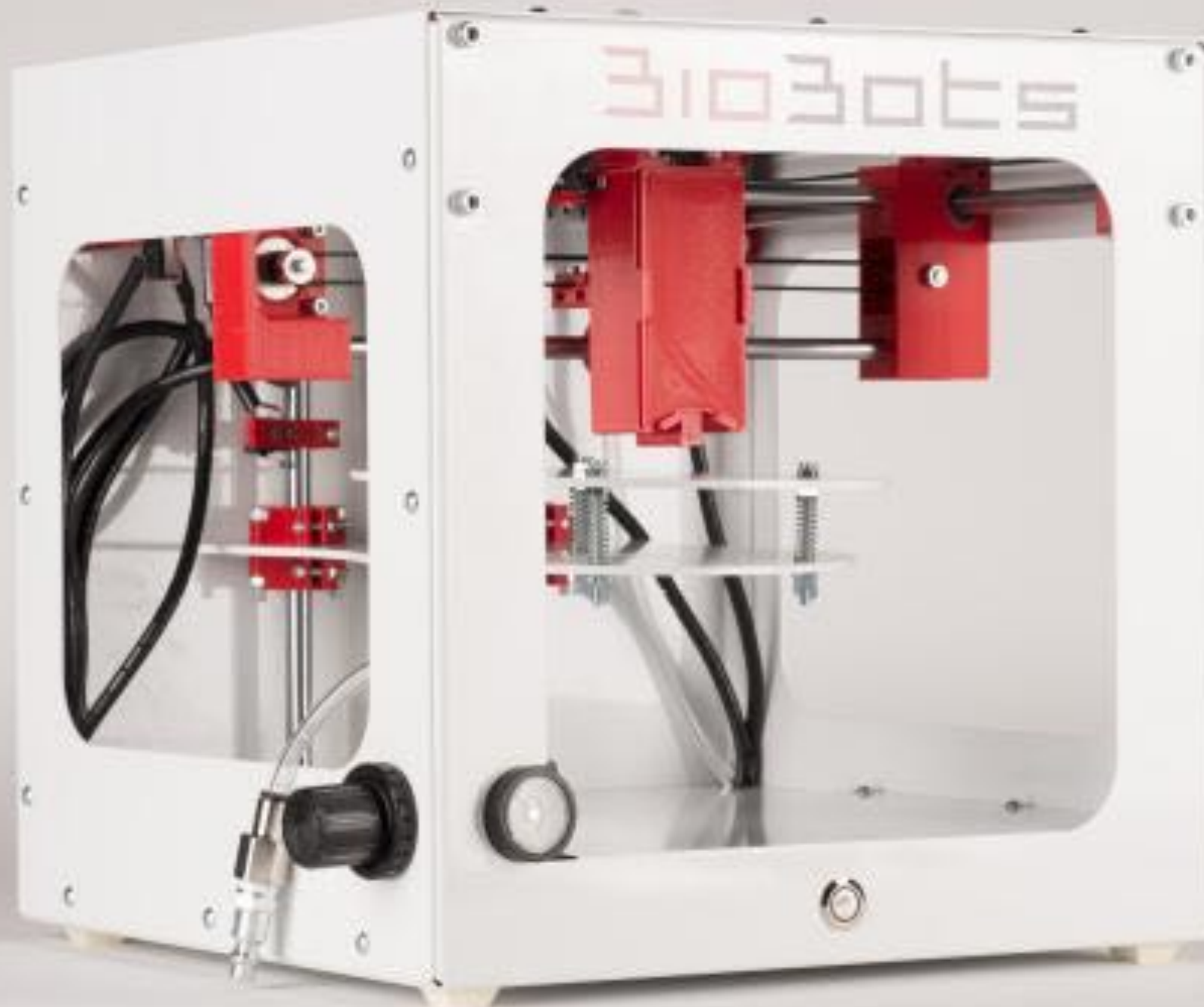



Syringe extruder





Bio-logic workshop

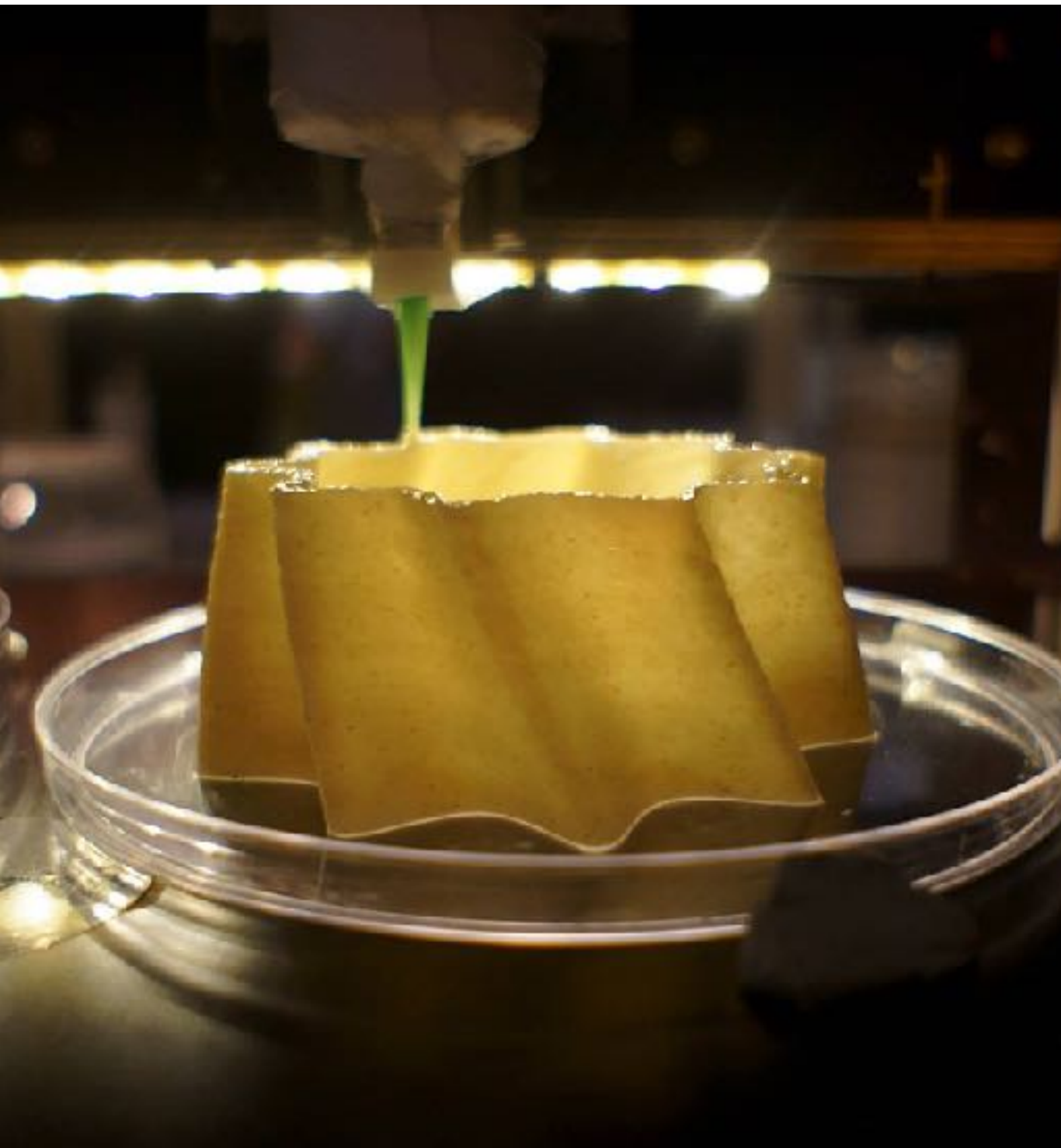

Maurizio Montalti in collaboration with Sonja Baeumel, Co-de-iT, WASP & Waag Society



Laser microscope

Cristina Cipriano



<http://www.thingiverse.com/thing:2754871>



Cristina Cipriano

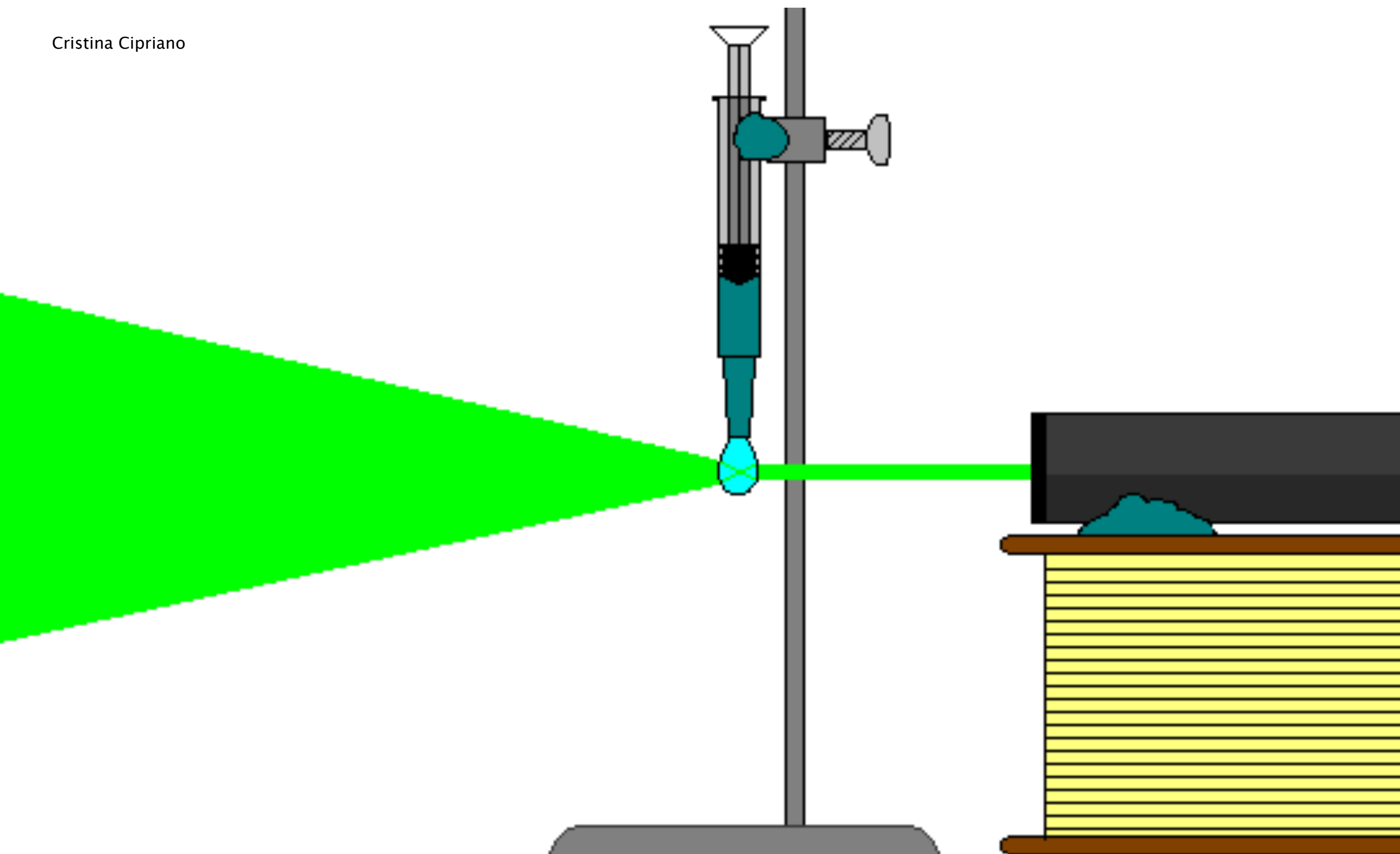

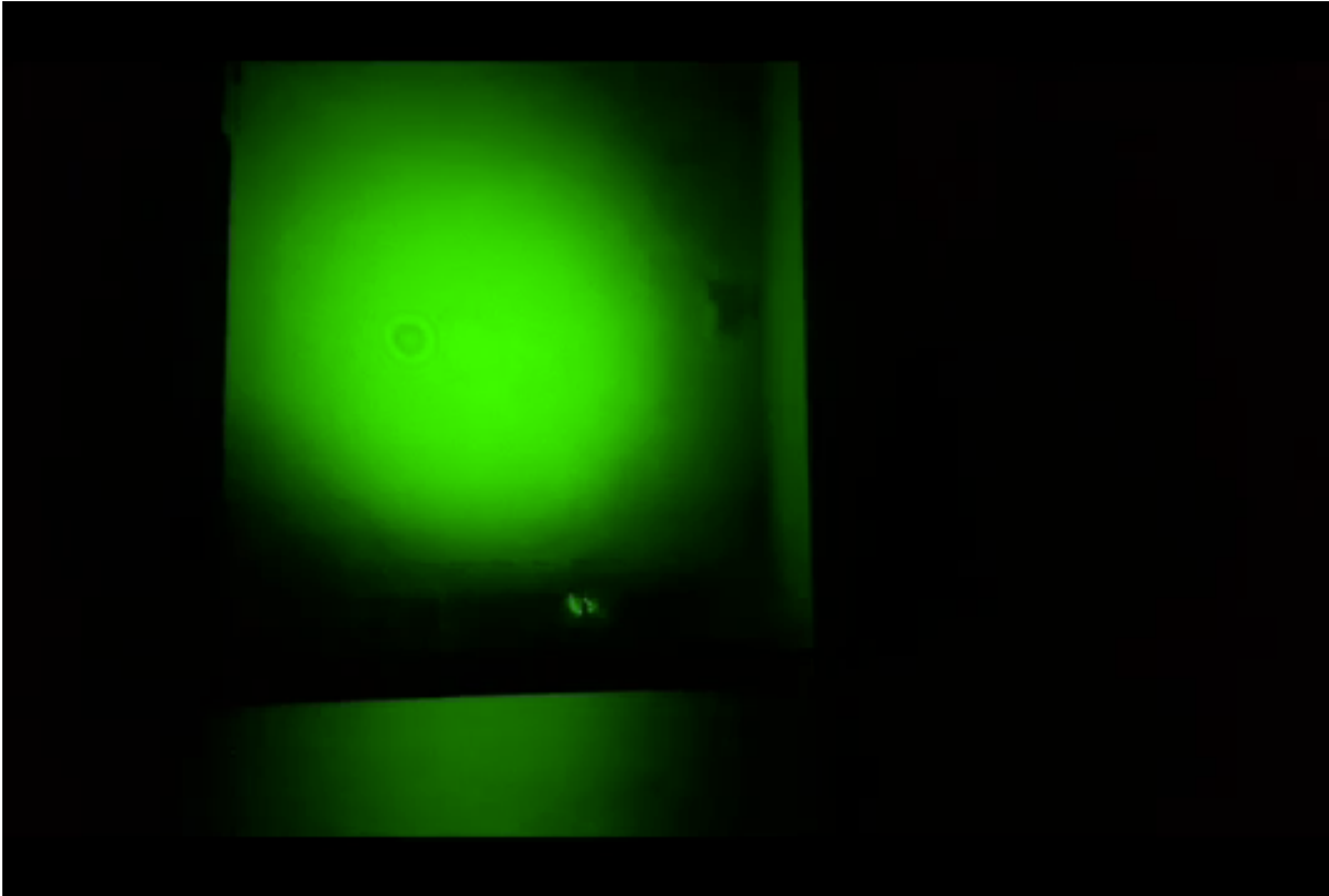



Foldscope

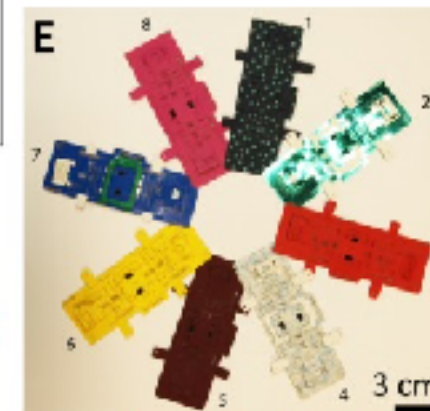
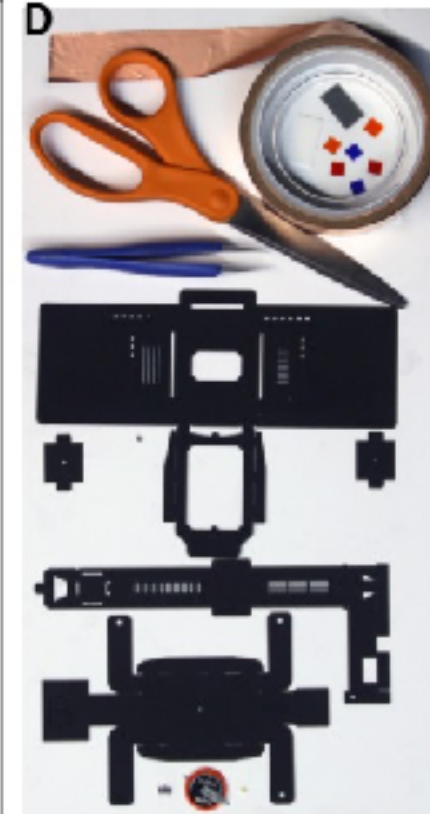
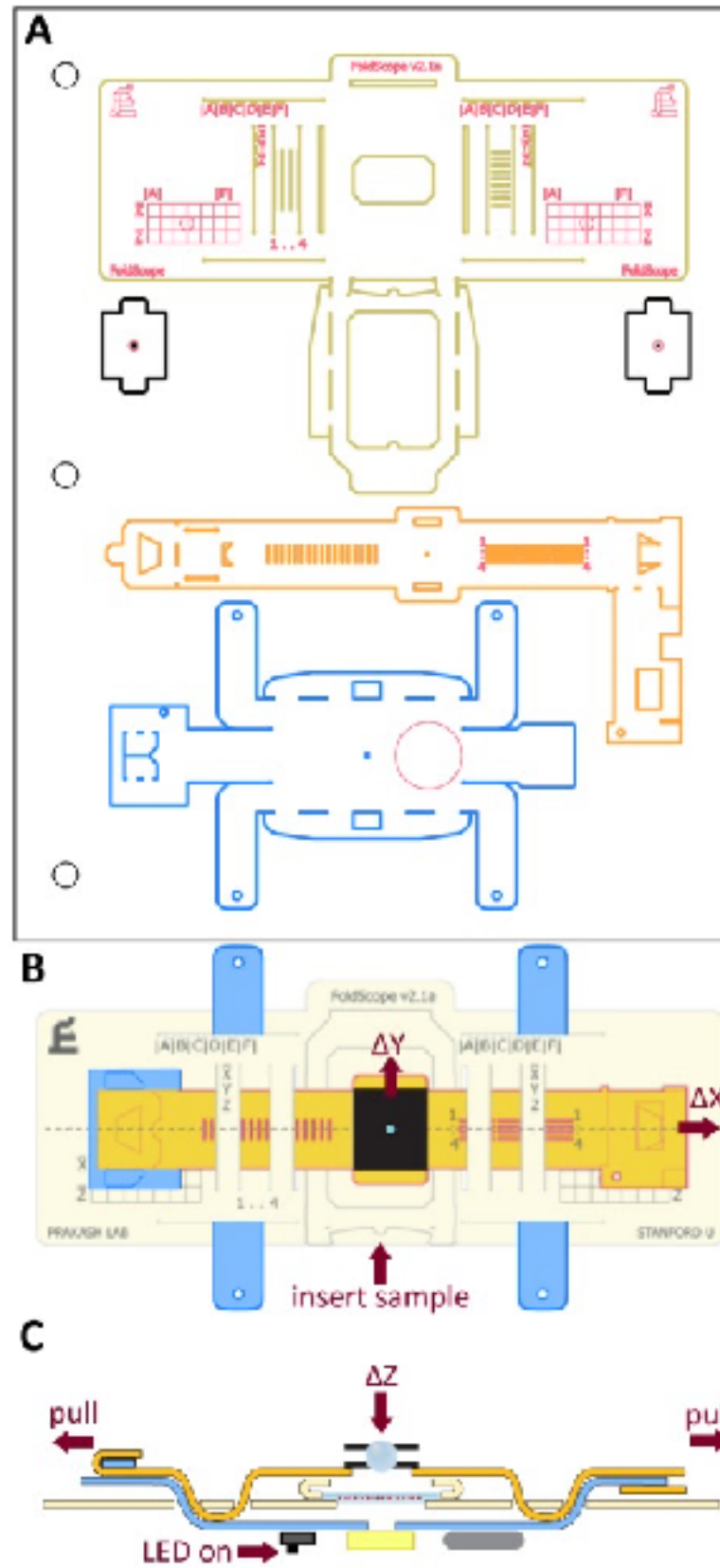

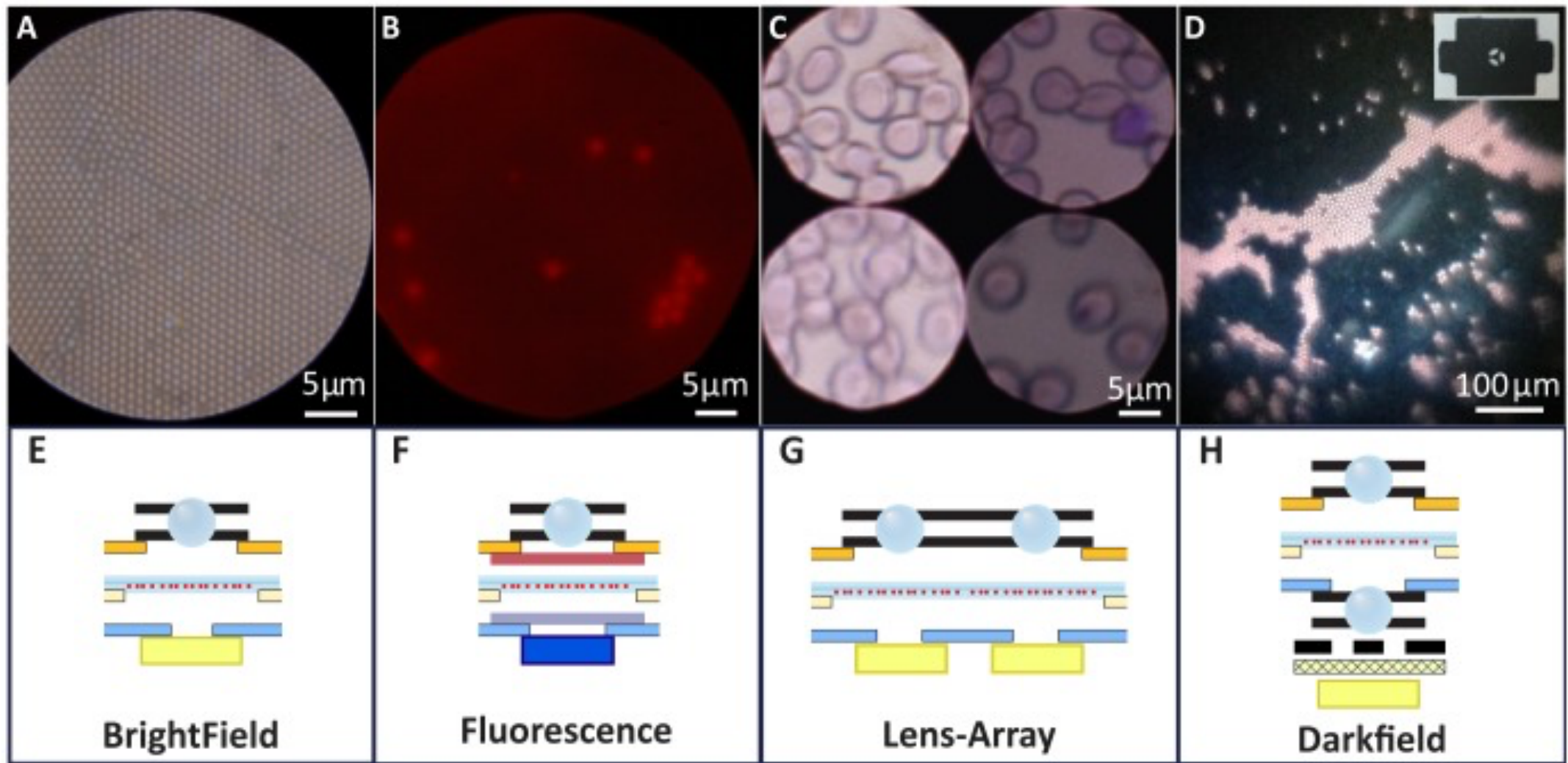



waag
wetlab amsterdam

Practicals



Anatomy of a microscope

You will learn how to operate a microscope

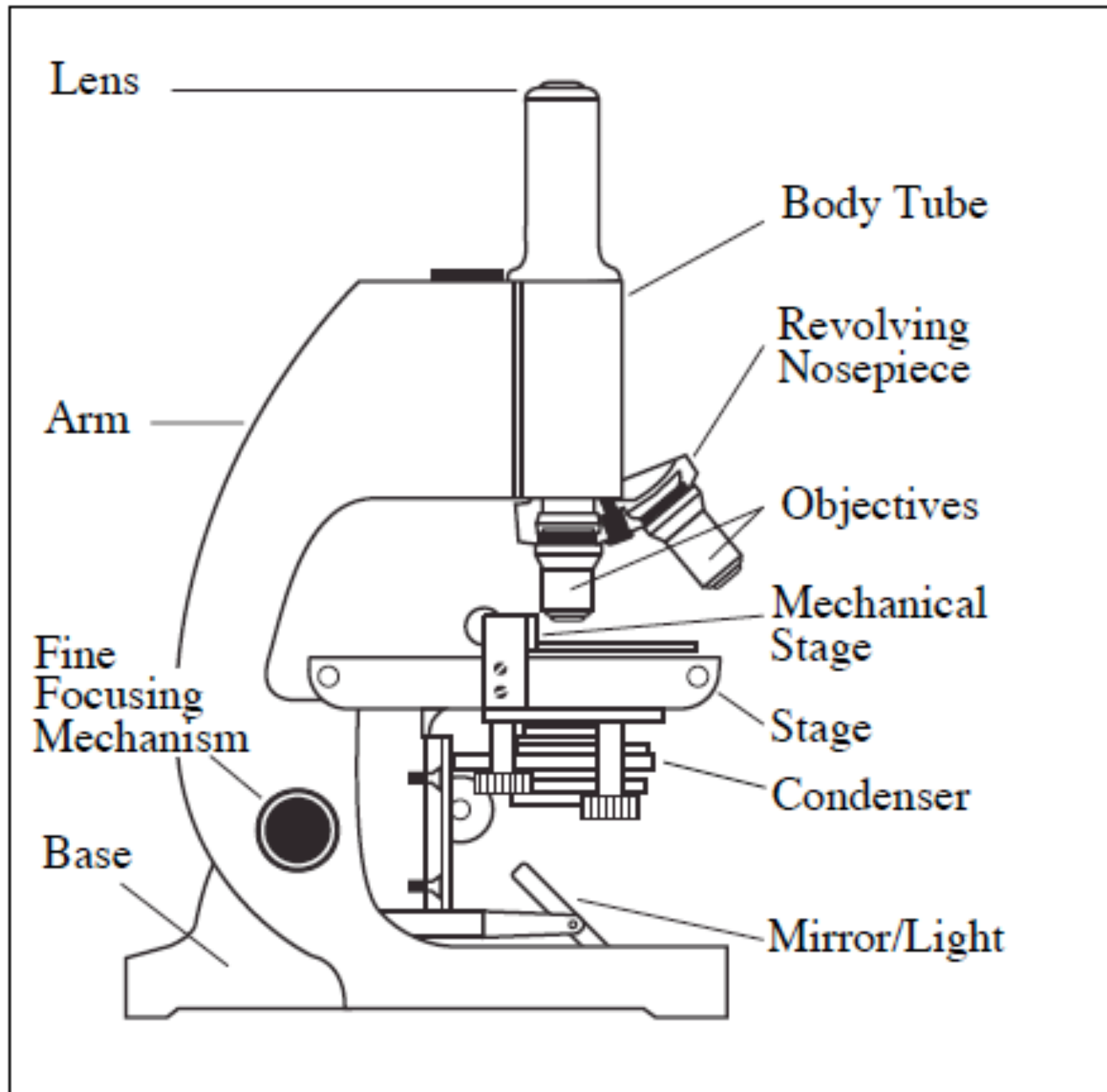

Staining: Loeffler / Gram / Alternative

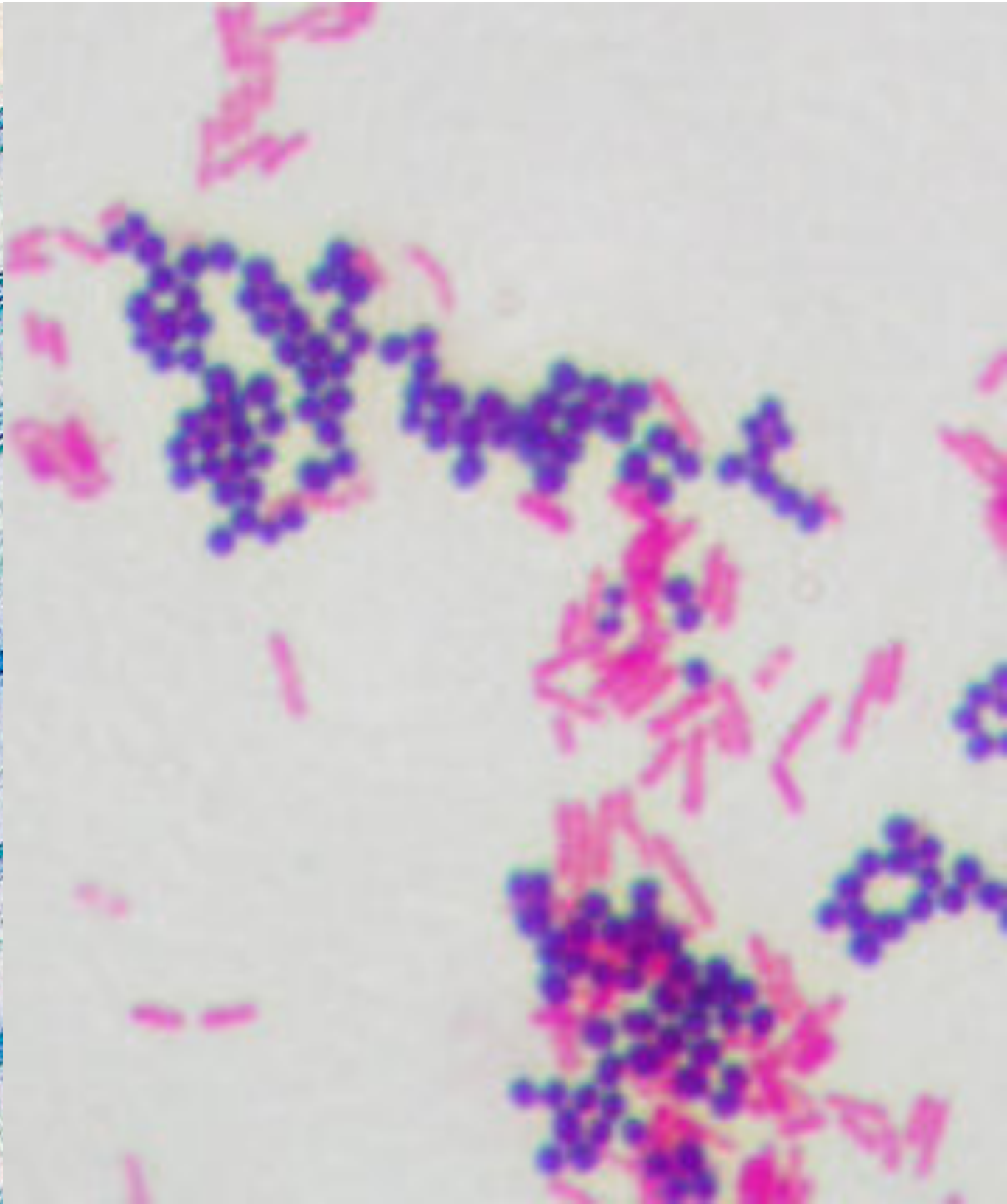
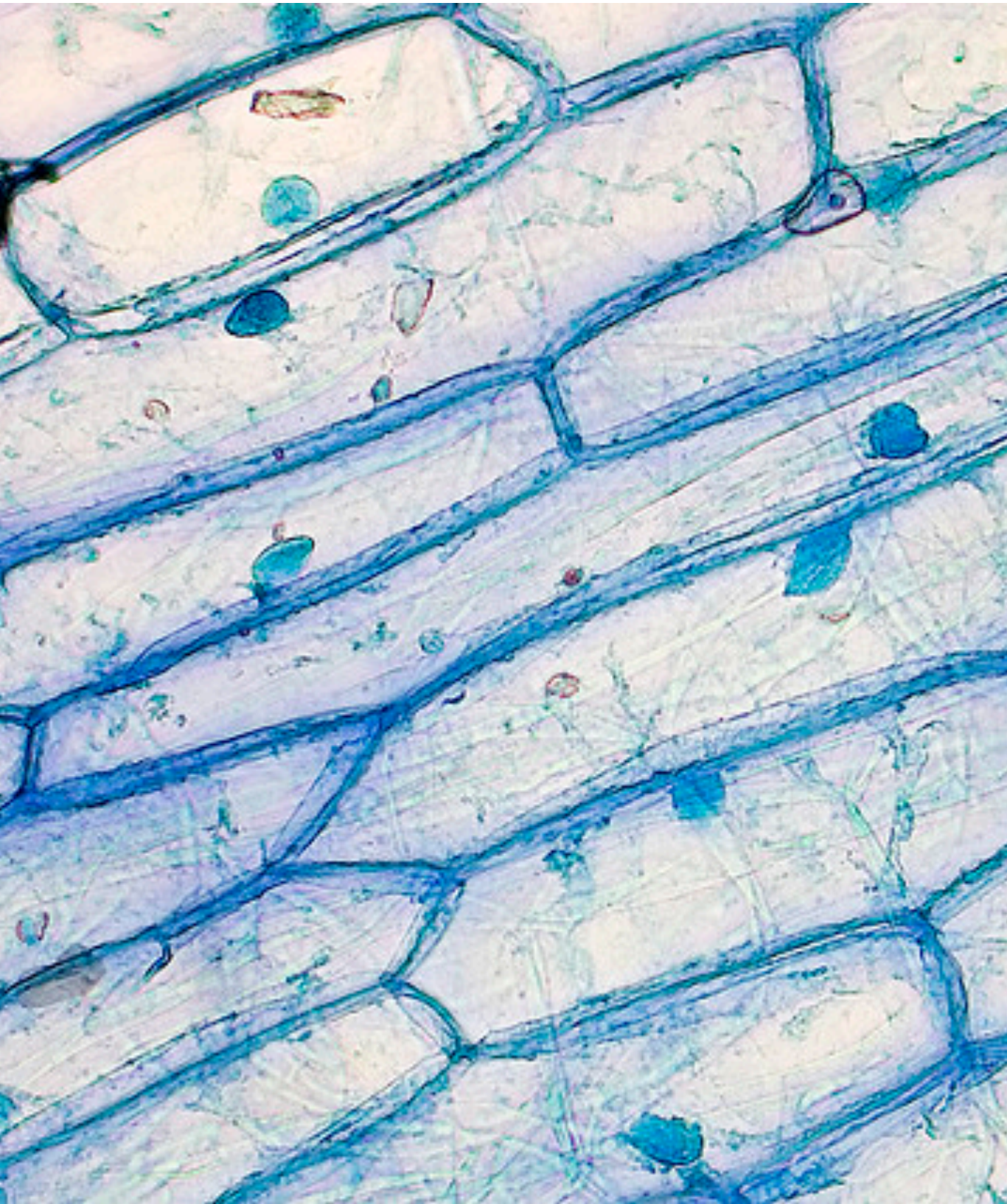



some

rights

reserved